

ACTIONclima[®]

Versione K - 4T



UTA

UNITA' CANALIZZABILI MEDIE
Ventilatore centrifugo / 4 - 6 Poli
230 Vac - 3 Velocità

MEDIUM TERMINAL UNITS
Centrifugal fan / 4 - 6 Poles
230 Vac - 3 Speed

ESP.max
200-350 Pa

TM-D03-61023010-R00

Manuale Tecnico: DIMENSIONI & DISEGNI

Technical Manual: DIMENSIONS & DRAWINGS



UTA ... K1 DX Versione orizzontale, canalizzabile, in doppio pannello a vista per impianto a 4 tubi – DX = Destra (STANDARD)
 Horizontal version, ductable, in double skin panel with cabinet for 4 pipe installation – DX = Right (STANDARD)

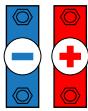

4 TUBI (2 batterie)
4 PIPE (2 coils)

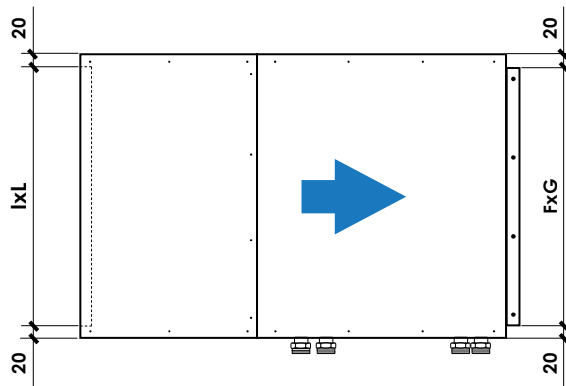
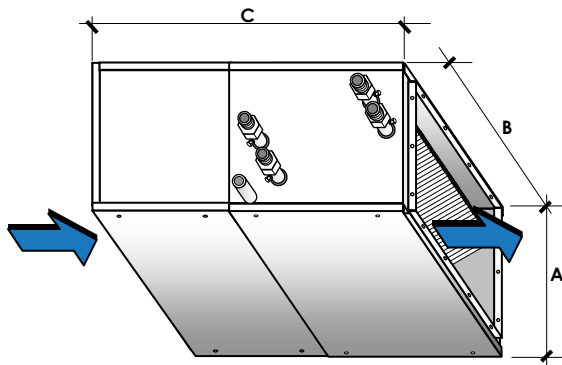
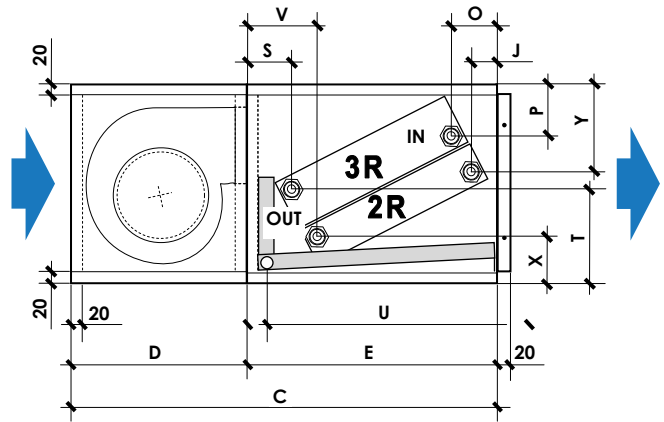
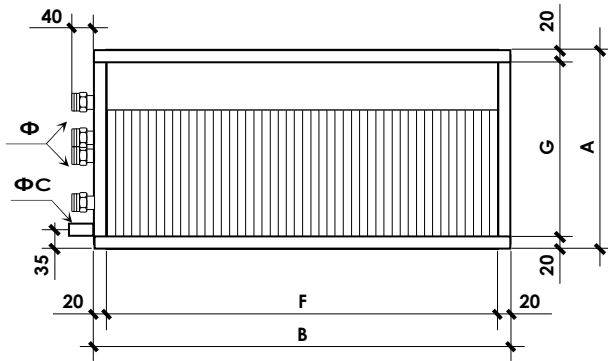

Dimensioni Generali unità – Unit general dimensions

Taglia - Size		UTA 100	UTA 200	UTA 300	UTA 400	UTA 500	UTA 600	UTA 1200	UTA 1300	UTA 1400	UTA 1500(*)	UTA 1600(*)	
Dimensioni Dimensions	A	mm	380	440	440	480	570	570	440	440	480	600	600
	B	mm	550	650	750	750	1.150	1.350	1.150	1.350	1.350	1.650	1.650
	C	mm	870	1.020	1.120	1.160	1.150	1.250	1.020	1.120	1.160	1.470	1.470
	D	mm	360	420	420	460	550	550	420	420	460	580	580
	E	mm	510	600	700	700	600	700	600	700	700	890	890
Bocca mandata aria Air supply outlet	F	mm	510	610	710	710	1.110	1.310	1.110	1.310	1.310	1.610	1.610
	G	mm	340	400	400	440	530	530	400	400	440	560	560
Bocca aspirazione aria Air intake inlet	I	mm	510	610	710	710	1.110	1.310	1.110	1.310	1.310	1.610	1.610
	L	mm	340	400	400	440	530	530	400	400	440	560	560
Scarico condensa Drain pipe	φ C	mm	30	30	30	30	30	30	30	30	30	30	30
	U	mm	470	560	660	660	560	660	560	660	660	850	850

Connessioni idrauliche – Water coil connections

3R(*) Cooling	S	mm	82	86	86	87	103	102	87	93	94	93	93
	T	mm	174	178	196	191	190	198	190	198	194	238	238
	O	mm	73	79	68	81	139	120	79	74	88	140	140
	P	mm	96	97	99	97	92	98	102	101	100	116	116
Attacchi – Connections φ (*)		DN	3/4" M	1" M	1" M	1" M	1"-1/4 M	1"-1/2 M	1"-1/4 M	1"-1/2 M	1"-1/2 M	1"-1/2 M	1"-1/2 M
Peso netto - Net weight		Kg	45,1	59,5	71,3	77,3	118,9	138,7	99,7	121,4	131,4	224,4	226,4
2R Heating	V	mm	114	123	114	122	165	150	124	120	132	146	146
	X	mm	106	105	120	117	128	122	111	112	112	127	127
	J	mm	46	48	44	52	86	73	47	44	55	94	94
	Y	mm	152	157	162	158	145	159	170	172	169	214	214
Attacchi – Connections φ (*)		DN	3/4" M	1" M	1" M	1" M	1"-1/4 M	1"-1/4 M	1"-1/4 M	1"-1/4 M	1"-1/4 M	1"-1/4 M	1"-1/4 M
Peso netto - Net weight		Kg	43,5	57,5	68,9	74,9	114,9	136,7	95,7	119,4	129,4	205,4	207,4

φ (*) : DN = Diametro nominale ; M = Attacchi idraulici batteria Gas Maschio
 Batteria (*) : le Taglie 15 e 16 montano batteria 4R anziché batteria 3R (R= n° di ranghi).
 Unità a 2 tubi = unità con 1 sola batteria caldo/freddo. Disponibili modelli con batteria 2R : 3R : 6R.
 DX = Attacchi idraulici a Destra (standard) ; SX = Attacchi idraulici a Sinistra (su richiesta)

φ (*) : DN = Nominal diameter ; M = Male gas water coil connections
 Coil (*) : sizes 15 and 16 are provided with 4R coil instead of 3R coil (R=n° of rows of the coil).
 2-pipe unit = unit with 1 heating/cooling coil only. Available models with 2R : 3R : 6R coil.
 DX = Right water coil connection (standard) ; SX = Left water coil connection (on request)

UTA ... K1 SX

Versione orizzontale, canalizzabile, in doppio pannello a vista per impianto a 4 tubi – SX = Sinistra (Su richiesta)
Horizontal version, ductable, in double skin panel with cabinet for 4 pipe installation – SX = Left (On request)



**4 TUBI (2 batterie)
4 PIPE (2 coils)**

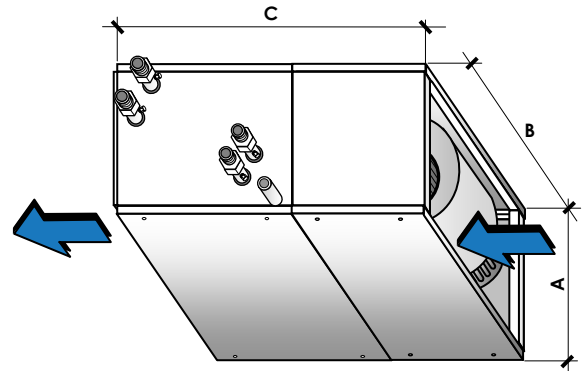
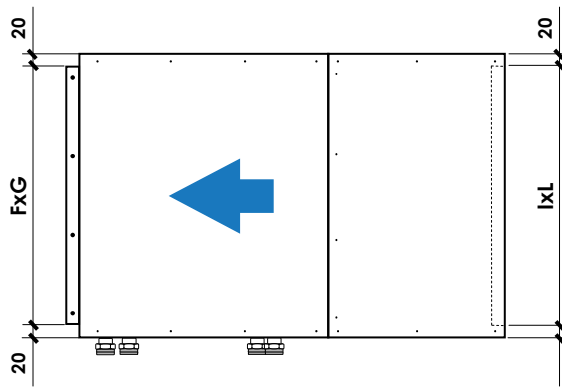
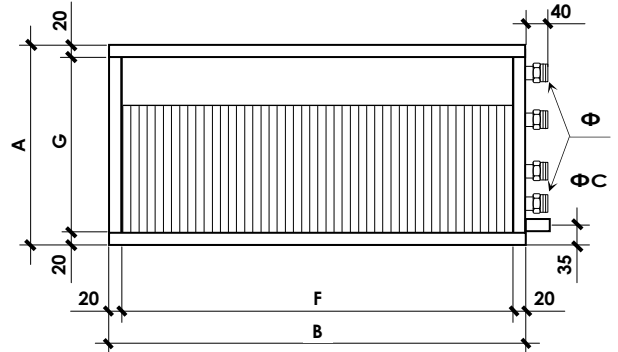
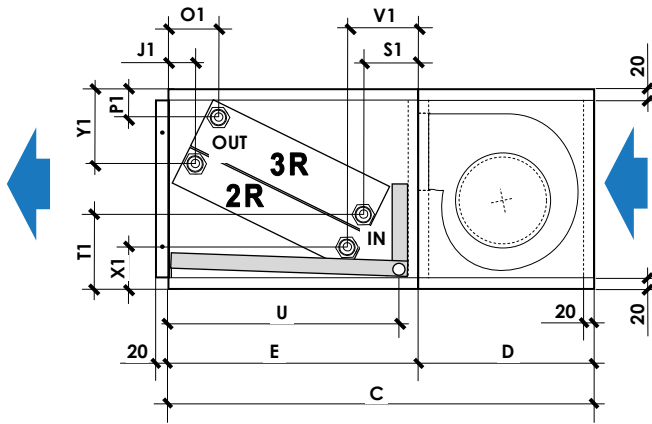

Dimensioni Generali unità – Unit general dimensions

Taglia - Size		UTA 100	UTA 200	UTA 300	UTA 400	UTA 500	UTA 600	UTA 1200	UTA 1300	UTA 1400	UTA 1500(*)	UTA 1600(*)	
Dimensioni Dimensions	A	mm	380	440	440	480	570	570	440	440	480	600	600
	B	mm	550	650	750	750	1.150	1.350	1.150	1.350	1.350	1.650	1.650
	C	mm	870	1.020	1.120	1.160	1.150	1.250	1.020	1.120	1.160	1.470	1.470
	D	mm	360	420	420	460	550	550	420	420	460	580	580
	E	mm	510	600	700	700	600	700	600	700	700	890	890
Bocca mandata aria Air supply outlet	F	mm	510	610	710	710	1.110	1.310	1.110	1.310	1.310	1.610	1.610
	G	mm	340	400	400	440	530	530	400	400	440	560	560
Bocca aspirazione aria Air intake inlet	I	mm	510	610	710	710	1.110	1.310	1.110	1.310	1.310	1.610	1.610
	L	mm	340	400	400	440	530	530	400	400	440	560	560
Scarico condensa Drain pipe	ϕ C	mm	30	30	30	30	30	30	30	30	30	30	30
	U	mm	470	560	660	660	560	660	560	660	850	850	

Connessioni idrauliche – Water coil connections

3R(*) Cooling	S1	mm	103	109	103	109	139	130	108	110	115	115	115
	T1	mm	128	133	149	145	155	157	145	151	148	189	189
	O1	mm	94	101	85	102	174	149	100	91	109	164	164
	P1	mm	50	52	52	51	57	57	57	54	54	65	65
Attacchi – Connections	ϕ (*)	DN	3/4" M	1" M	1" M	1" M	1"-1/4 M	1"-1/2 M	1"-1/4 M	1"-1/2 M	1"-1/2 M	1"-1/2 M	1"-1/2 M
Peso netto - Net weight		Kg	45,1	59,5	71,3	77,3	118,9	138,7	99,7	121,4	131,4	224,4	226,4
2R Heating	V1	mm	129	140	127	137	192	172	140	133	147	163	163
	X1	mm	72	72	85	84	102	92	77	78	79	87	87
	J1	mm	62	65	57	68	112	94	63	57	71	109	109
	Y1	mm	118	124	128	125	119	129	137	137	136	181	181
Attacchi – Connections	ϕ (*)	DN	3/4" M	1" M	1" M	1" M	1"-1/4 M	1"-1/4 M	1"-1/4 M	1"-1/4 M	1"-1/4 M	1"-1/4 M	1"-1/4 M
Peso netto - Net weight		Kg	43,5	57,5	68,9	74,9	114,9	136,7	95,7	119,4	129,4	205,4	207,4

ϕ (*): DN = Diametro nominale ; M = Attacchi idraulici batteria Gas Maschio

Batteria (*): le Taglie 15 e 16 montano batteria 4R anziché batteria 3R (R= n° di ranghi).
Unità a 2 tubi = unità con 1 sola batteria caldo/freddo. Disponibili modelli con batteria 2R : 3R : 6R.

DX = Attacchi idraulici a Destra (standard) ; SX = Attacchi idraulici a Sinistra (su richiesta)

ϕ (*): DN = Nominal diameter ; M = Male gas water coil connections

Coil (*): sizes 15 and 16 are provided with 4R coil instead of 3R coil (R=n° of rows of the coil).
2-pipe unit = unit with 1 heating/cooling coil only. Available models with 2R : 3R : 6R coil.

DX = Right water coil connection (standard) ; SX = Left water coil connection (on request)

UTA ... K2 DX

Versione orizzontale, Aspirazione aria frontale, in doppio pannello a vista per impianto a 4 tubi – DX = Destra (STANDARD)
Horizontal version, Frontal air intake, in double skin panel with cabinet for 4 pipe installation – DX = Right (STANDARD)

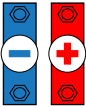

**4 TUBI (2 batterie)
4 PIPE (2 coils)**

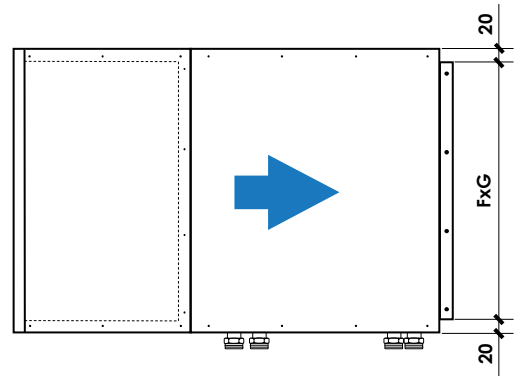
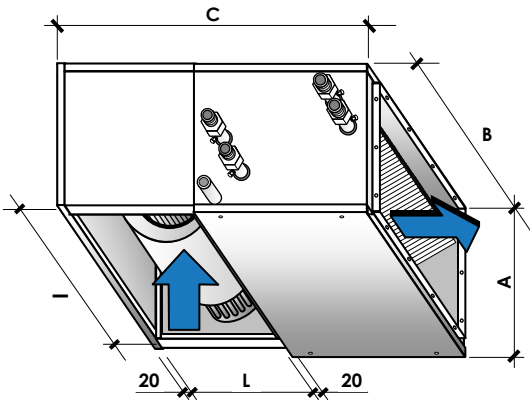
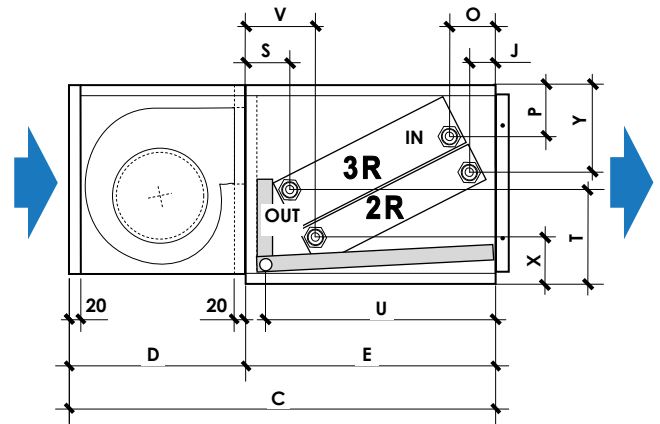
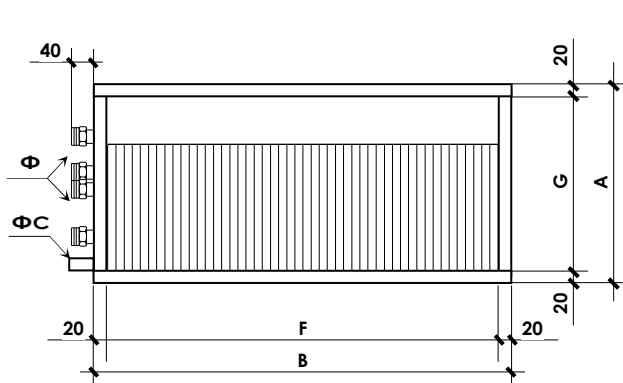

Dimensioni Generali unità – Unit general dimensions

Taglia - Size		UTA 100	UTA 200	UTA 300	UTA 400	UTA 500	UTA 600	UTA 1200	UTA 1300	UTA 1400	UTA 1500(*)	UTA 1600(*)	
Dimensioni Dimensions	A	mm	380	440	440	480	570	570	440	440	480	600	600
	B	mm	550	650	750	750	1.150	1.350	1.150	1.350	1.350	1.650	1.650
	C	mm	890	1.040	1.140	1.180	1.170	1.270	1.040	1.140	1.180	1.490	1.490
	D	mm	380	440	440	480	570	570	440	440	480	600	600
	E	mm	510	600	700	700	600	700	600	700	700	890	890
Bocca mandata aria Air supply outlet	F	mm	510	610	710	710	1.110	1.310	1.110	1.310	1.310	1.610	1.610
	G	mm	340	400	400	440	530	530	400	400	440	560	560
Bocca aspirazione aria Air intake inlet	I	mm	510	610	710	710	1.110	1.310	1.110	1.310	1.310	1.610	1.610
	L	mm	340	400	400	440	530	530	400	400	440	560	560
Scarico condensa Drain pipe	φ C	mm	30	30	30	30	30	30	30	30	30	30	30
	U	mm	470	560	660	660	560	660	560	660	660	850	850

Connessioni idrauliche – Water coil connections

3R(*) Cooling	S	mm	82	86	86	87	103	102	87	93	94	93	93
	T	mm	174	178	196	191	190	198	190	198	194	238	238
	O	mm	73	79	68	81	139	120	79	74	88	140	140
	P	mm	96	97	99	97	92	98	102	101	100	116	116
Attacchi – Connections φ (*)		DN	3/4" M	1" M	1" M	1" M	1"-1/4 M	1"-1/2 M	1"-1/4 M	1"-1/2 M	1"-1/2 M	1"-1/2 M	1"-1/2 M
Peso netto - Net weight		Kg	45,1	59,5	71,3	77,3	118,9	138,7	99,7	121,4	131,4	224,4	226,4
2R Heating	V	mm	114	123	114	122	165	150	124	120	132	145	145
	X	mm	106	105	120	117	128	122	111	112	112	127	127
	J	mm	46	48	44	52	86	73	47	44	55	94	94
	Y	mm	152	157	162	158	145	159	170	172	169	214	214
Attacchi – Connections φ (*)		DN	3/4" M	1" M	1" M	1" M	1"-1/4 M	1"-1/4 M	1"-1/4 M	1"-1/4 M	1"-1/4 M	1"-1/4 M	1"-1/4 M
Peso netto - Net weight		Kg	43,5	57,5	68,9	74,9	114,9	136,7	95,7	119,4	129,4	205,4	207,4

φ (*): DN = Diametro nominale ; M = Attacchi idraulici batteria Gas Maschio
Batteria (*): le Taglie 15 e 16 montano batteria 4R anziché batteria 3R (R= n° di ranghi).
Unità a 2 tubi = unità con 1 sola batteria calda/freddo. Disponibili modelli con batteria 2R : 3R : 6R.
DX = Attacchi idraulici a Destra (standard) ; SX = Attacchi idraulici a Sinistra (su richiesta)

φ (*): DN = Nominal diameter ; M = Male gas water coil connections
Coil (*): sizes 15 and 16 are provided with 4R coil instead of 3R coil (R=n° of rows of the coil).
2-pipe unit = unit with 1 heating/cooling coil only. Available models with 2R : 3R : 6R coil.
DX = Right water coil connection (standard) ; SX = Left water coil connection (on request)

UTA ... K2 SX Versione orizzontale, Aspirazione aria frontale, in doppio pannello a vista per impianto a 4 tubi – SX = Sinistra
 Horizontal version, Frontal air intake, in double skin panel with cabinet for 4 pipe installation – SX = Left

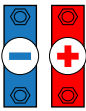

4 TUBI (2 batterie)
4 PIPE (2 coils)

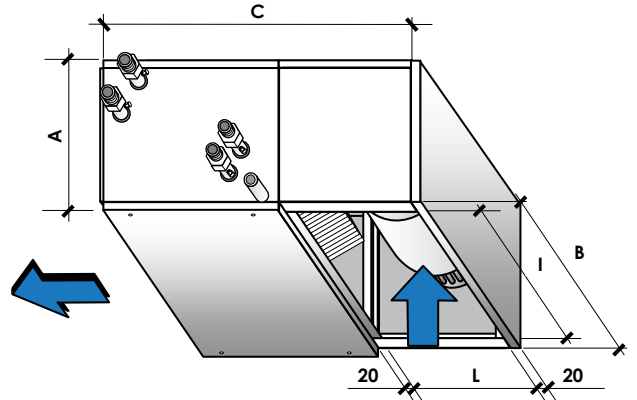
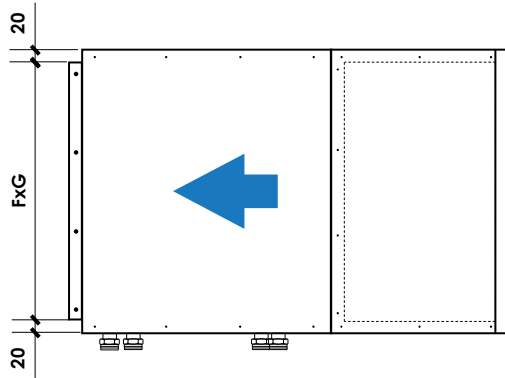
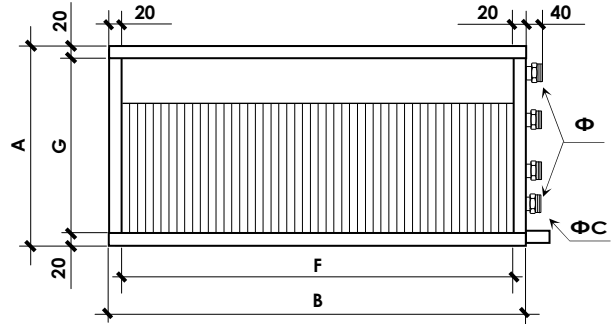
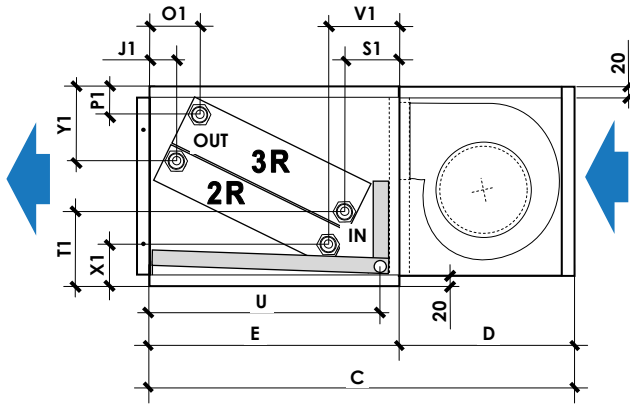

Dimensioni Generali unità – Unit general dimensions

Taglia - Size		UTA 100	UTA 200	UTA 300	UTA 400	UTA 500	UTA 600	UTA 1200	UTA 1300	UTA 1400	UTA 1500(*)	UTA 1600(*)	
Dimensioni Dimensions	A	mm	380	440	440	480	570	570	440	440	480	600	600
	B	mm	550	650	750	750	1.150	1.350	1.150	1.350	1.350	1.650	1.650
	C	mm	890	1.040	1.140	1.180	1.170	1.270	1.040	1.140	1.180	1.490	1.490
	D	mm	380	440	440	480	570	570	440	440	480	600	600
	E	mm	510	600	700	700	600	700	600	700	700	890	890
Bocca mandata aria Air supply outlet	F	mm	510	610	710	710	1.110	1.310	1.110	1.310	1.310	1.610	1.610
	G	mm	340	400	400	440	530	530	400	400	440	560	560
Bocca aspirazione aria Air intake inlet	I	mm	510	610	710	710	1.110	1.310	1.110	1.310	1.310	1.610	1.610
	L	mm	340	400	400	440	530	530	400	400	440	560	560
Scarico condensa Drain pipe	φ C	mm	30	30	30	30	30	30	30	30	30	30	30
	U	mm	470	560	660	660	560	660	560	660	660	850	850

Connessioni idrauliche – Water coil connections

	S1	mm	103	109	103	109	139	130	108	110	115	115	115
	T1	mm	128	133	149	145	155	157	145	151	148	189	189
	O1	mm	94	101	85	102	174	149	100	91	109	164	164
	P1	mm	50	52	52	51	57	57	57	54	54	65	65
Attacchi – Connections φ(*)		DN	3/4" M	1" M	1" M	1" M	1"-1/4 M	1"-1/2 M	1"-1/4 M	1"-1/2 M	1"-1/2 M	1"-1/2 M	1"-1/2 M
Peso netto - Net weight		Kg	45,1	59,5	71,3	77,3	118,9	138,7	99,7	121,4	131,4	224,4	226,4
	V1	mm	129	140	127	137	192	172	140	133	147	163	163
	X1	mm	72	72	85	84	102	92	77	78	79	87	87
	J1	mm	62	65	57	68	112	94	63	57	71	109	109
	Y1	mm	118	124	128	125	119	129	137	137	136	181	181
Attacchi – Connections φ(*)		DN	3/4" M	1" M	1" M	1" M	1"-1/4 M	1"-1/4 M	1"-1/4 M	1"-1/4 M	1"-1/4 M	1"-1/4 M	1"-1/4 M
Peso netto - Net weight		Kg	43,5	57,5	68,9	74,9	114,9	136,7	95,7	119,4	129,4	205,4	207,4

φ(*) : DN = Diametro nominale ; M = Attacchi idraulici batteria Gas Maschio
 Batteria (*) : le Taglie 15 e 16 montano batteria 4R anziché batteria 3R (R= n° di ranghi).
 Unità a 2 tubi = unità con 1 sola batteria caldo/freddo. Disponibili modelli con batteria 2R : 3R : 6R.
 DX = Attacchi idraulici a Destra (standard) ; SX = Attacchi idraulici a Sinistra (su richiesta)

φ(*) : DN = Nominal diameter ; M = Male gas water coil connections
 Coil (*) : sizes 15 and 16 are provided with 4R coil instead of 3R coil (R=n° of rows of the coil).
 2-pipe unit = unit with 1 heating/cooling coil only. Available models with 2R : 3R : 6R coil.
 DX = Right water coil connection (standard) ; SX = Left water coil connection (on request)

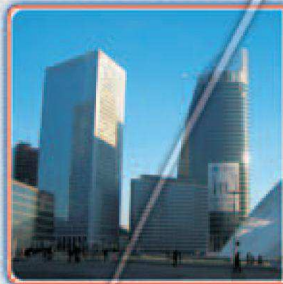
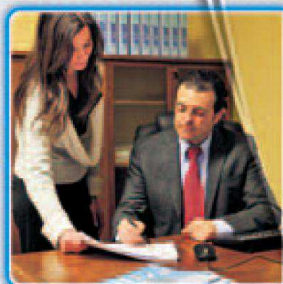

ACTIONclima[®]

ACTIONCLIMA S.r.l. - 31030 BIBAN FRAZIONE DI CARBONERA - Via Biban, 54
TREVISO (ITALY) - Tel.: (+39) 0422-699923 - Fax.: (+39) 0422-445768
www.actionclima.it - e-mail: info@actionclima.it